

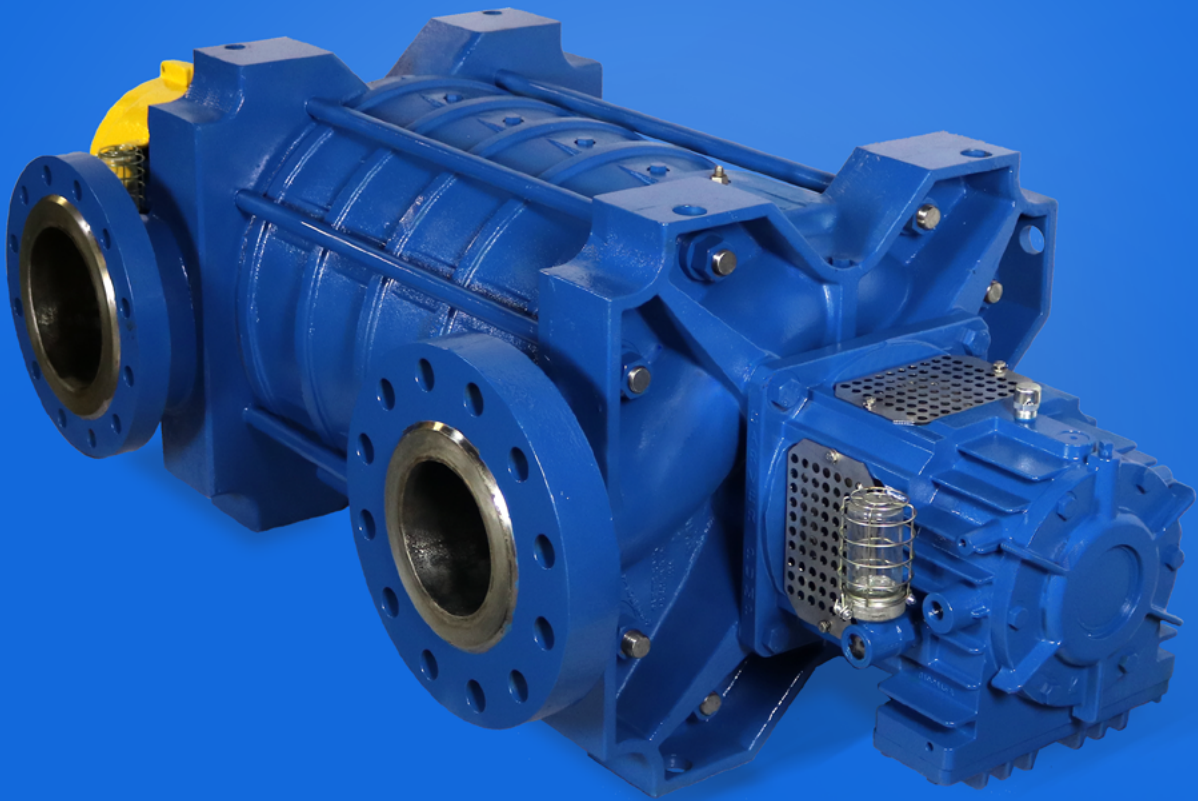

CARVER PUMP™

Built for purpose



RS

Multistage Ring Section Pump
for pressure to 1,500 PSI



RS

The RS is our process duty, horizontal ring section multistage pump. Designed for moderate to high-pressure pumping, the RS is available in seven basic sizes with overall performance to 2,600 HP.

The RS is offered with Class 300 ANSI R.F. inlet flanges and Class 600 or 900 ANSI R.F. discharge flanges, depending on the pressures and number of stages involved. Hydraulic performance extends to 2,000 GPM and 3,400 ft. TDH, making it ideally suited for the most demanding industrial and process applications.

The RS design incorporates a product-lubricated, advanced composite material, sleeve-type radial bearing at the outboard (discharge) end. The thrust bearings are two matched angular contact ball bearings located at the inboard (suction) end of the pump. An optional outboard mechanical seal with an inboard radial ball bearing is also available. The RS has oil-lubricated ball bearings, which can be water cooled. Larger units can also be fan cooled.

The available materials of construction, from ductile iron to duplex stainless steel, offer combinations suitable for all applications from general water services to light abrasives and corrosive applications. Our proprietary advanced composite material, available for wear rings and interstage bushings, offers high-temperature performance, and exceptional resistance to wear and corrosion.

Many other options and arrangements, such as turbine and magnetic drive units, are also available. These options, together with all the value-added features shown on the following pages, offer the benefits of:

MAXIMUM SAFETY

MAXIMUM INSTALLATION FLEXIBILITY

MAXIMUM FLUID COMPATIBILITY

HIGHER EFFICIENCIES

LONGER COMPONENT LIFE

MINIMAL DOWNTIME

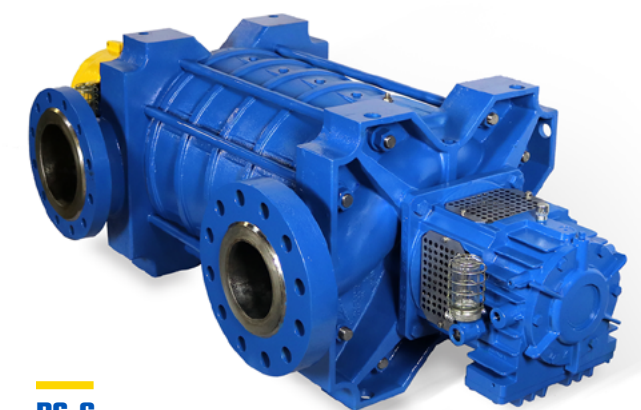

RS-G

APPLICATIONS



Oil & Gas

The transfer of crude oil from producer to end user required a pump that could provide sustained high pressure and hold up to the harsh, changing climate of Canada's Oil Sands region. Carver Pump's RS (Ring Section) pump line was an easy choice for the LACT system booster pumps needed in this application. Our RS pumps produce up to 3400 ft TDH (Total Dynamic Head) and can easily pump oil long distances over changing elevations.



The above units are the outdoor units and these are the indoor units for the same company. These stations are built to determine the actual crude oil that is pumped out of the well head and then "transferred" to the next client. It requires that the crude oil be accurately measured so that the producing company get paid properly for the oil that is being transferred to the refiner or the next customer. Sometimes it just requires a lower head pump to transfer the product to the next client – however accurate measurement is always crucial.



Produced Water

This system was designed for flexibility and performance, with each of the 12 D-sized pumps delivering up to 700 gallons per minute. In addition, the pumps were built with a blind stage, so that discharge pressure can be upgraded in the future without any change to system piping. The modular nature of the design allowed us to precisely meet the conditions of service.

Boiler Feed

Two RS-D size 6x3x8 4-stage pumps in all CD4MCu duplex SS construction feed an auxiliary boiler in a combined-cycle power plant. The pumps shown were sold as complete units with fabricated steel base plates, spacer couplings, and 300 HP electric motors. This model uses oil-lubricated, water-cooled, angular-contact ball bearings on both shaft ends and John Crane Type 5611 cartridge seals per the spec. These seals are cooled through the use of a Plan 23 flush.



Amine Recirculation

Our high-pressure RS Series pumps drive an amine recirculation system at this natural gas plant. The 'sour' gas captured and scrubbed with lean amine removing hydrogen sulfide (H₂S) and carbon dioxide (CO₂), making it suitable for injection into the pipelines.



Other Applications

- Agriculture irrigation
- Chemical and light hydrocarbon transfer
- Coating and surface treatment Desalination and reverse osmosis
- High rise building sprinklers
- Paper mill shower water
- Pressure boosting systems
- Sanitary wash down services
- Ski resort snowmaking systems Equipment lube and seal oil supply
- High-pressure injection applications



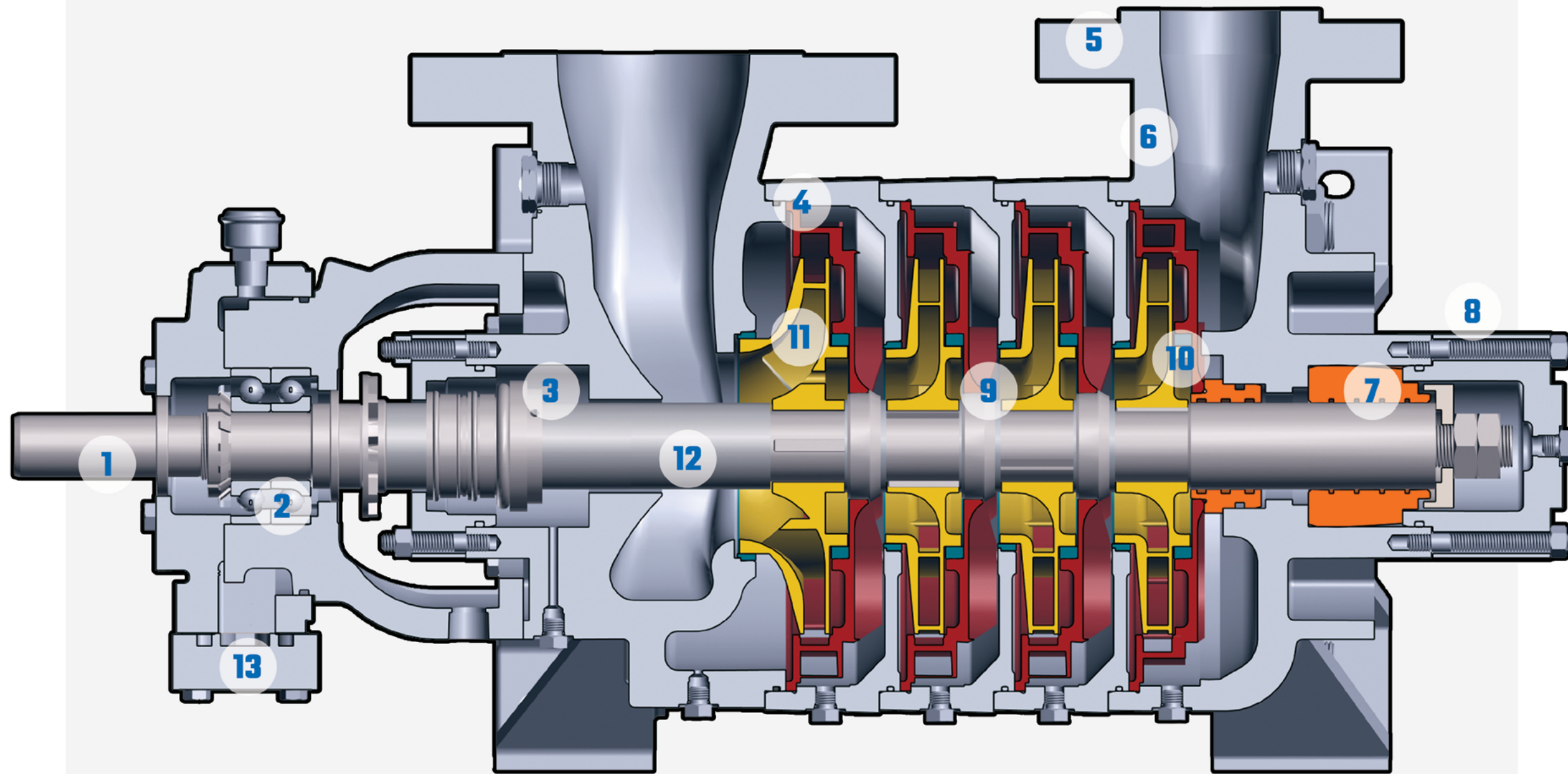

- 1 SHAFTS**
17-4 PH stainless steel as standard
- 2 BALL BEARINGS**
Oil-lubricated angular contact ball bearings to handle axial thrust in either direction
- 3 STUFFING BOX**
Accepts either component or cartridge-type mechanical seals
- 4 O-RINGS**
O-ring sealed casing and interstages assure leak-free operation
- 5 FLANGES**
Class 300 ANSI R.F. inlet flange and Class 600 or 900 ANSI R.F. discharge flanges
- 6 CASING**
Ductile iron or CD4MCuN duplex stainless steel as standard
- 7 SLEEVE BEARINGS**
Radial sleeve-type bearing made of standard Carver composite material
- 8 OPTIONAL BEARING DESIGN**
Optional matched angular contact ball bearings on outboard end with grooved radial ball bearing on inboard
- 9 INTERSTAGE BUSHING**
Replaceable interstage bushing made of composite or hardened metal
- 10 WEAR RINGS**
Replaceable front and rear wear rings at each pump stage as standard
- 11 FIRST STAGE IMPELLER**
Special low-NPSH first-stage impeller
- 12 SHAFT SLEEVES**
Stainless steel shaft sleeves as standard
- 13 OPTIONAL COOLER**
Included when temperatures exceed 220° F

■ Sleeve Bearing
 ■ Diffuser
 ■ Wear Ring
 ■ Impeller

SEAL OPTIONS

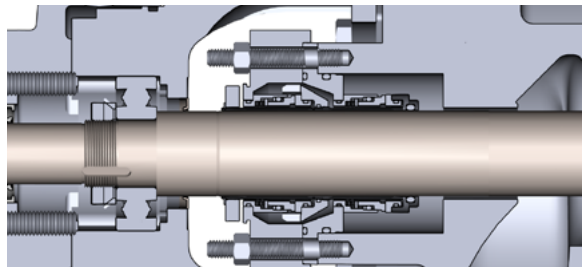

CARTRIDGE - SINGLE OR DUAL

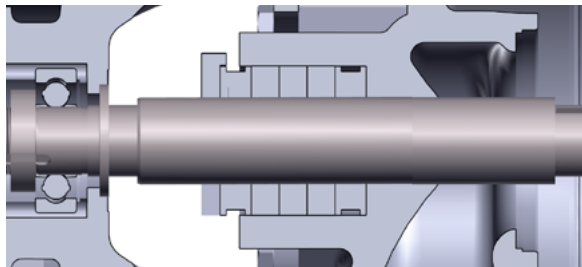

PACKING

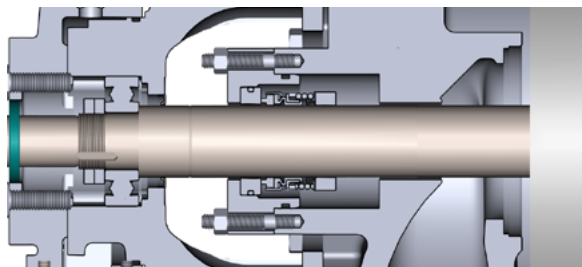

COMPONENT - SINGLE



RS-C Multi-Stage with API Plan 52/Tandem Seals



Air-cooled seal support system for applications where external cooling fluid is unavailable Plan 23

HYDRAULIC COVERAGE

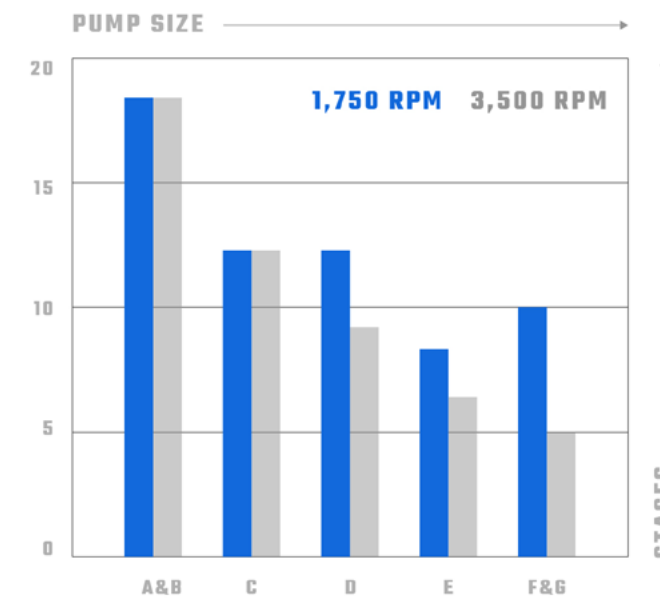
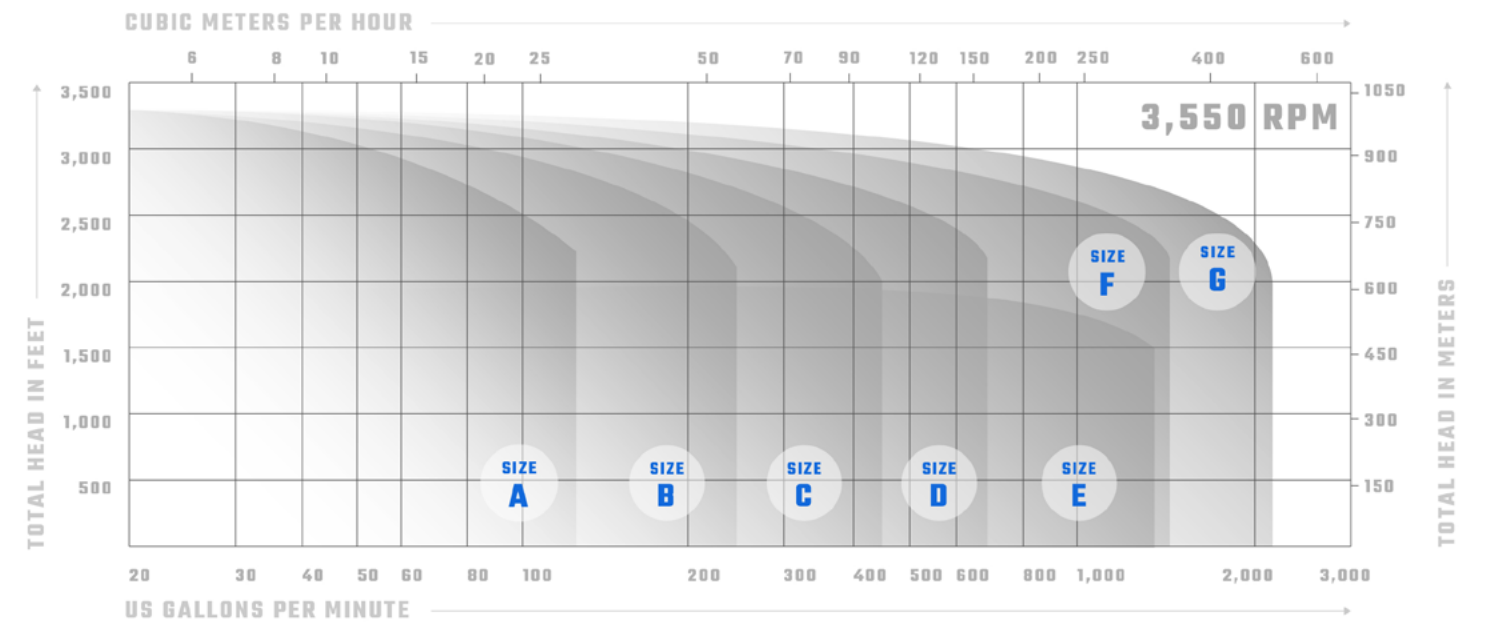

WHY AN RS?

- The ability to select the number of stages to meet the design point makes the RS a more cost-effective solution.
- Interstage diffusers minimize radial loads, for longer seal and bearing life, while carefully controlling fluid flow, for smooth and quiet operation.
- Lower rotational speed vs. high-speed gearbox pumps results in lower NPSHr, more durability and longer life.
- Suction and discharge casings can be rotated to meet a variety of piping configurations.
- Hydraulically balanced thrust loads at each stage preserve bearing life.
- Water and fan cooling are available for high-temperature applications.

HYDRAULICS

Flows to 2,000 GPM (454 m³/hr)

Heads to 3,400 feet (1,000 m)

Pressures to 1,500 psig (100 bar)

Temperatures from -20° F to 300° F (-30° C to 149° C)

Speeds to 3,550 RPM

STANDARD MATERIALS

Casing Ductile Iron or CD4MCuN

Impeller Cast Iron or CD4MCuN

Diffuser Cast Iron or CD4MCuN

Shaft 17-4PH SS

Sleeve Bearing Composite Material

Other Materials Available Upon Request

MECHANICAL DATA

Rotation Clockwise as Standard

Flange Positions 3 Positions Available

Suction Flange Class 300 ANSI R.F.

Discharge Flange Class 600 or 900 ANSI R.F.

Bearings Oil Lubricated

DISCOVER OUR PUMPS



**GH - HORIZONTAL
END-SUCTION PUMP**



**RS - MULTISTAGE
RING SECTION PUMP**



**API MAXUM OH2 -
END-SUCTION PUMP**



**KWP - NON-CLOGGING
PROCESS PUMP**



**850 - HORIZONTAL
FILTRATE PUMP**



**MAXUM OH1- HEAVY-
DUTY, HORIZONTAL
END-SUCTION PUMP**



**855 - TANK-
MOUNTED FILTRATE
PUMP**



**RSV - VERTICAL
IN-LINE MULTISTAGE
PUMP**



**VLO - VERTICAL LUBE
OIL PUMP**



**G2C - VERTICAL
CANTILEVER PUMP**



**G2S - VERTICAL
SUMP PUMP**



**OH3 - VERTICAL
IN-LINE PUMP**



**KEF - SELF PRIME
PUMP**



**M SERIES - ASTM
F998 CLOSE-
COUPLED PUMP**



**DELTA P - PACKAGED
PUMP SYSTEM**



**DELTA P - UL508A
LISTED CONTROL
PANELS**



80 years of experience

Since we built our first pumps in 1938, Carver Pump has become recognized as one of the leading centrifugal pump companies, building pumps to the most demanding engineering specifications and military standards in the world.

We were one of the first American pump companies to attain ISO 9001 certification – the most recognized standard for quality in the world. This certification is your assurance that our commitment

to quality includes not only our hardware, but also superior customer service, leading-edge R&D, and continuous improvement in everything we do.

So whether the job is refueling fighter jets on the deck of an aircraft carrier, supplying paint to an auto assembly line, or bringing water to the fountain in a city park, we put our reputation on the line everyday with every pump we build.

Contact us

2415 Park Avenue
Muscatine, Iowa 52761-5691
USA

(563) 263-3410
sales@carverpump.com
www.carverpump.com