

AFR-64L

Lean-Burn Air/Fuel Ratio Control System

The AFR-64L air/fuel ratio controller provides state-of-the-art engine control in one simple, easy-to-use product.

Automatic Operation: No operator intervention needed – the AFR-64L controller automatically tracks multiple factors, including engine load, tailpipe emissions and more, then precisely adjusts the air/fuel mix to maximize fuel efficiency, minimize engine emissions, improve engine performance and reduce maintenance costs.

Emissions Compliance: The AFR-64L controller optimizes the lean-burn air/fuel mix to maintain targeted emissions levels over varying engine loads, speeds, fuel quality and ambient conditions.

Cost Savings: Pinpoint performance problems and avoid detonation. The AFR-64L controller's advanced troubleshooting and diagnostics cover 76 critical operating parameters, allowing the operator to cut the costs of maintenance, labor, downtime and replacement parts.

Take control over your engine needs – engine diagnostics, emissions control, fully automatic operation – the AFR-64L does it all for you.

Technical Features

- Fast, easy, low-cost installation
- Fits virtually any lean-burn, spark-ignited, carbureted natural-gas industrial engine
- Windows-based platform compatible with most computers
- Software, upgrades and documentation available on disk or online
- High-speed full-authority butterfly fuel control valves for quick response time
- Comprehensive 76 fault diagnostics
- Data plotting for easy, accurate troubleshooting
- Separate alarm and shut-down dry contact relays
- Closed loop, exhaust oxygen feedback control
- Variable set point for exhaust oxygen control delivers real-time response to varying engine loads and transients – perfect for generator-sets and other high-variance applications
- Catalyst temperature monitoring to protect the catalyst from engine fueling malfunctions



Dimensions

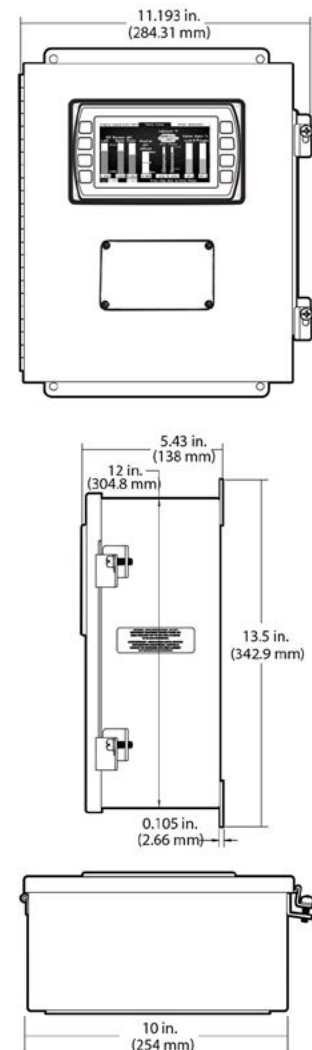

Technical Features - continued

- Open loop/feed forward control combined with closed loop exhaust gas oxygen sensor feedback and a super fast-acting fuel control valve
- Allows for rapid response to engine load changes
- Vital for generator sets and other applications with severe engine load variations
- Helps maintain compliance even in the event of an oxygen sensor failure
- Drives up to two control banks for operation on V type engine configurations
- Fast-acting Full-Authority Fuel Control Valve controls all fuel delivered to the engine
- Full-color Graphic Display - optional, enclosure or remote mounted
- RS-485/MODBUS communications support (available)
- NEMA 12 enclosure without display, IP 66 enclosure with optional display
- 12 / 24 VDC Nominal

How To Order

Options listed below applies to all Air/Fuel Controllers. All configurations may not be available. Call your sales representative or FW Murphy for more information. Sample order AFR-PD-L-64L-2-2-FA50 below.

